

# MASONRY DESIGN USING TMS 402-11 AND 2012 IBC

Presented by  
Miller Consulting Engineers, Inc.  
Lane P. Jobe, SE

Co-authored by Ray Miller, SE



An in-depth review of masonry code changes from the 2009 to 2012 IBC and 2008 to 2011 TMS as they relate to structural design and construction.

# The IBC References the MSJC

## Minimum Requirements for Design and Construction of Structural Masonry:

- Code and Commentary:

TMS 402-11/ACI 530-11/ASCE 5-11

- Specifications and Commentary:

TMS 602-11/ACI 530.1-11/ASCE 6-11

# Masonry Noted in IBC Chapters:

- Chapter 14 - Veneer
- Chapter 17 - Special Inspection and Testing
- Chapter 18 - Foundations
- Chapter 21 - Masonry

Design loads are taken from the *Minimum Design Loads for Buildings and Other Structures* (ASCE 7-10) or the IBC.

## 2011 MSJC CODE & SPECIFICATION

### CODE & COMMENTARY

Both on same page  
Side by side

CHAPTER 1 - General Design Requirements for Masonry

CHAPTER 2 - Allowable Stress Design of Masonry

CHAPTER 3 - Strength Design of Masonry

CHAPTER 4 - Prestressed Masonry

CHAPTER 5 - Empirical Design of Masonry

CHAPTER 6 - Veneer

CHAPTER 7 - Glass Unit Masonry

CHAPTER 8 - Strength Design of Autoclaved Aerated  
Concrete (AAC) Concrete

APPENDIX B - Design of Masonry Infill

### SPECIFICATION & COMMENTARY

Both on same page  
Side by side

PART 1 - General

PART 2 - Products

PART 3 - Executions

Specification Checklist

Mandatory Requirements Checklist

Optional Requirements Checklist

# Overview of Some Major Changes In The 2011 MSJC

1. No 1/3 Increase in Stress Under ASD for Wind or Seismic Loading
2. ASD Stress Increases
3. Deep Beam Provisions
4. Direct Design Handbook
5. Appendix B – Masonry Infill

# New Terms

## INFILL

Masonry constructed in the plane and bounded by a structural frame (Appendix B).

## BOUNDING FRAME

Column, beams, and/or slabs surrounding a masonry infill and providing structural support (Appendix B).

# New Terms

## BEAMS

1. Design requirements for masonry beams shall apply to masonry lintels (TMS 402-11, 1.13).
2. Length of bearing for beams on the supports shall be a minimum of 4 inches in the direction of the span (TMS 402-11, 1.13.1.3).



# New Terms

## DEEP BEAM

A beam with an effective span-to-depth ratio ( $l_{eff} / d_v$ ) less than 3 for a continuous span and less than 2 for a simple span (1.13.2)

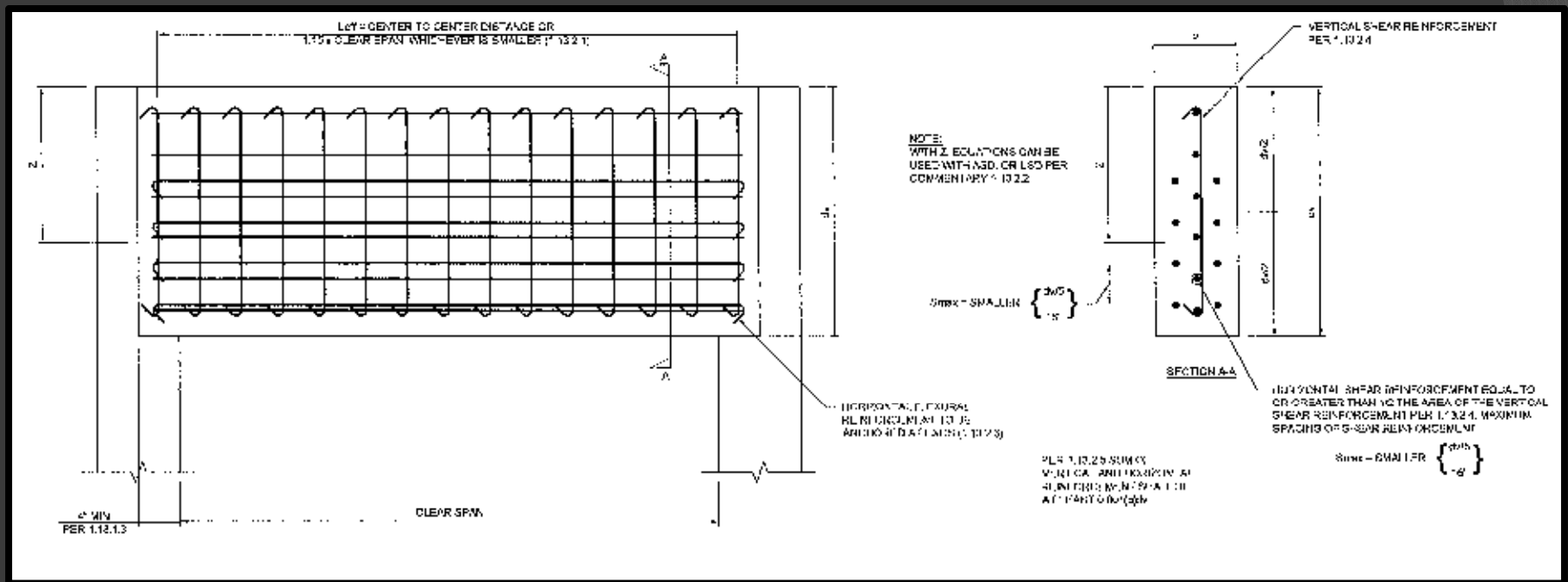

## 1.13.2 Deep Beams

1. Effective span length ( $\ell_{eff}$ ) shall be the center-to-center distance between supports or 1.15 times the clear span, whichever is smaller (1.13.2.1).
2. Internal lever arm ( $z$ ) is the distance between the compressive and tensile forces (1.13.2.2).

## 1.13.2.2 Deep Beams

Simply Supported Beams:

(1) When  $1 \leq \ell_{eff} / d_v < 2$

$$z = 0.2 (\ell_{eff} + 2 d_v)$$

Eq. 1-2a

(2) When  $\ell_{eff} / d_v < 1$

$$z = 0.6 \ell_{eff}$$

Eq. 1-2b

## 1.13.2.2 Deep Beams

### Continuous Spans:

(1) When  $1 \leq \ell_{eff} / d_v < 3$

$$z = 0.2 (\ell_{eff} + 1.5 d_v) \quad \text{Eq. 1-3a}$$

(2) When  $\ell_{eff} / d_v < 1$

$$z = 0.5 \ell_{eff} \quad \text{Eq. 1-3b}$$

## 1.13.2.3 Deep Beams

### Flexural Reinforcement:

Distributed horizontal flexural reinforcement in tension zone for one-half of  $d_v$  with a maximum spacing of one-fifth  $d_v$  or 16 inches. Horizontal flexural reinforcement shall be anchored at face of supports.

## 1.13.2.4 Deep Beams

### Minimum Shear Reinforcement:

- (1) Minimum area of vertical shear reinforcement equal to  $0.0007 b d_v$  .
- (2) Horizontal shear reinforcement shall have an area equal or greater than one half the area of the vertical shear reinforcement.

## 1.13.2.4 Deep Beams

### Minimum Shear Reinforcement:

- (3) Maximum spacing of shear reinforcement shall not exceed one-fifth  $d_v$  or 16 inches.

## 1.13.2.5 Deep Beams

### Total Reinforcement:

The sum of cross-sectional areas of horizontal and vertical reinforcement shall be at least 0.001 times  $bd_v$ , gross cross-sectional area.



## 1.14.1.1 Columns

### Dimensional Limits:

- (a) The distance between lateral supports of a column shall not exceed 99 times least radius of gyration,  $r$ .
- (b) Minimum side dimension 8 inches.

## 1.15 Pilasters

1. Masonry shall be running bond.
2. Walls shall be anchored by steel connectors grouted into the wall at a maximum spacing of 48 inches.
3. Design for shear at interfaces (1.9.4.2.2 – 1.9.4.2.4).

## 1.17.1 Anchor Bolts

Placement for anchor bolts at top of grout cells and bond beams and in drilled holes in the face shells.

Grout surround is no longer required for a bolt through a CMU face-shell.

## 1.18.3.2.3.1 Minimum Reinforcement Requirements

Vertical and horizontal reinforcement adjacent to openings smaller than 16 inches need not be provided unless distributed reinforcement is interrupted.

## 1.18.3.2.6 Special Reinforced Masonry Shear Walls

### 1.18.3.2.6(d)

#### Hooked Reinforcing Steel Requirements:

TMS402-11 Special Reinforced Masonry Shear Walls require that the shear reinforcement be anchored around vertical reinforcement with a standard hook.

Section 1.18.4.4.2.3 requires that standard hooked bar anchorage is to either be a 135 degree or 180 degree hook.

## Hooked Reinforcing Steel Requirements: *The Masonry Society Interpretation*

- Hooked bar anchorage is only required when shear steel is required with equation 2-25 when designing shear walls with working stress design.
- When designing shear walls using ultimate strength design with equation 3-20.
- If shear reinforcement is not required by the design equation, hooked shear reinforcement is not required and straight bars may be utilized.

# Hooked Bar Anchorage Requirements

## Horizontal Reinforcing at End of Wall

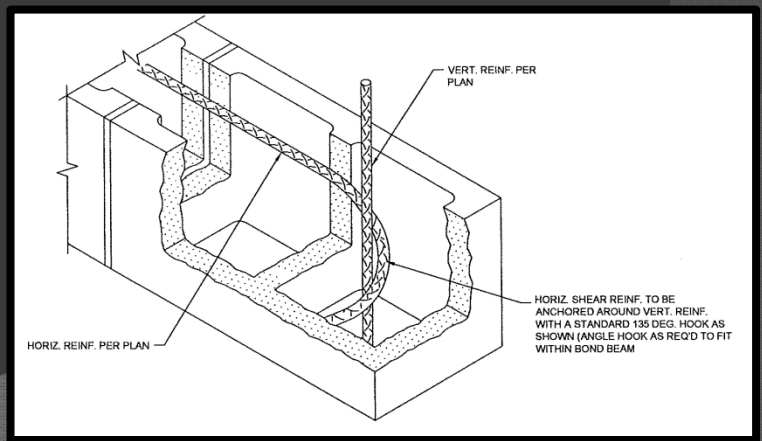
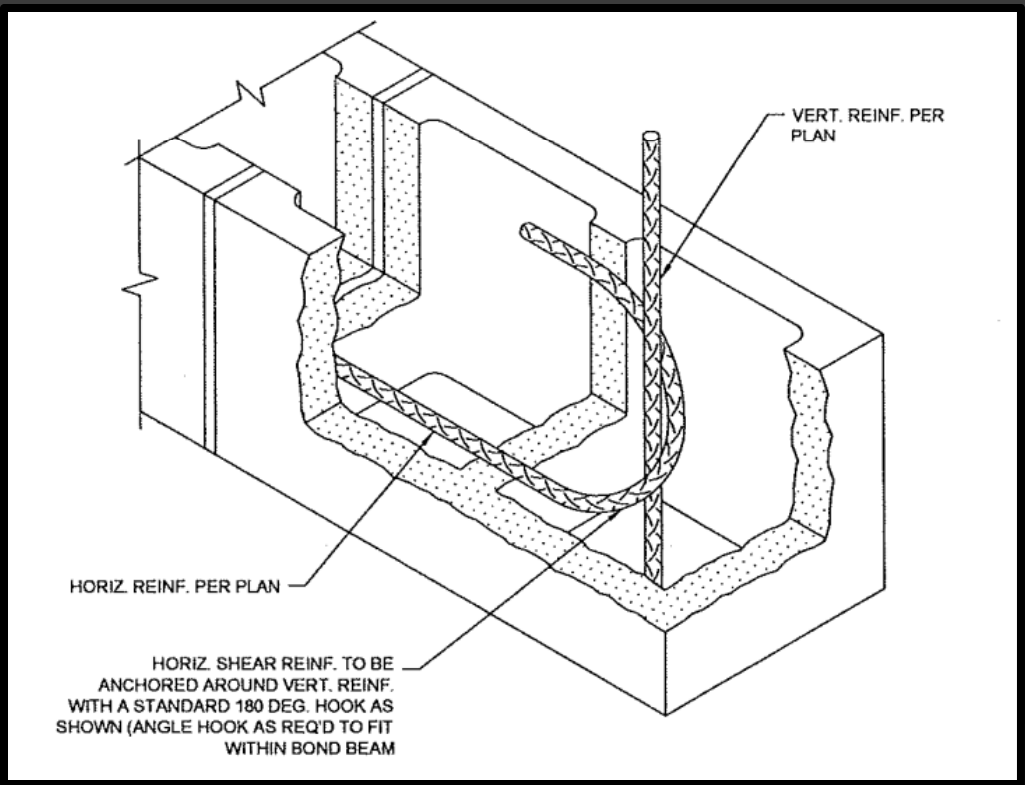

## 1.18.3.2.12 Special Reinforced Prestressed Masonry Shear Walls

- d. Dead load axial forces shall include the effect prestress force  $A_{ps} f_{se}$
- e. Design shear strength criteria



# Table 1.19.2

## Level B Quality Assurance

MINIMUM INSPECTION				
Inspection Task	Frequency <sup>(a)</sup>		Reference for Criteria	
	Continuous	Periodic	TMS 402/ ACI 530/ ASCE 5	TMS 602/ ACI 530.1/ ASCE 6
1. Verify compliance with the approved submittals		X		Art. 1.5
2. As masonry construction begins, verify that the following are in compliance:				
a. Proportions of site-prepared mortar		X		Art. 2.1, 2.6 A
b. Construction of mortar joints		X		Art. 3.3 B
c. Grade and size of prestressing tendons and anchorages		X		Art. 2.4 B, 2.4 H
d. Location of reinforcement, connectors, and prestressing tendons and anchorages		X		Art. 3.4, 3.6 A
e. Prestressing technique		X		Art. 3.6 B
f. Properties of thin-bed mortar for AAC masonry	X <sup>(b)</sup>	X <sup>(c)</sup>		Art. 2.1 C

*Reprinted with the permission of TMS*

# Table 1.19.3

## Level C Quality Assurance

<b>MINIMUM INSPECTION</b>				
<b>Inspection Task</b>	<b>Frequency <sup>(a)</sup></b>		<b>Reference for Criteria</b>	
	Continuous	Periodic	TMS 402/ ACI 530/ ASCE 5	TMS 602/ ACI 530.1/ ASCE 6
1. Verify compliance with the approved submittals		X		Art. 1.5
2. Verify that the following are in compliance:				
a. Proportions of site-mixed mortar, grout and prestressing grout for bonded tendons		X		Art. 2.1, 2.6 A, 2.6 B, 2.6 C, 2.4 G.1.b
b. Grade, type, and size of reinforcement and anchor bolts, and prestressing tendons and anchorages		X	Sec. 1.16	Art. 2.4, 3.4
c. Placement of masonry units and construction of mortar joints		X		Art. 3.3 B
d. Placement of reinforcement, connectors, and prestressing tendons and anchorages	X		Sec. 1.16	Art. 3.2 E, 3.4, 3.6 A
e. Grout space prior to grouting	X			Art. 3.2 D, 3.2 F
f. Placement of grout and prestressing grout for bonded tendons	X			Art. 3.5, 3.6 C

*Reprinted with the permission of TMS*

## 1.20.2.1 Construction

### Embedded Conduits, Pipes, and Sleeves:

Conduits, pipes and sleeves shall not be considered to be structural replacements for the displaced masonry. The masonry design shall consider the structural effects of this displaced masonry.

# Table 1.20.1 Grout Space Requirements

Grout type <sup>1</sup>	Maximum grout pour height, ft (m)	Minimum clear width of grout space, <sup>2,3</sup> in. (mm)	Minimum clear grout space dimensions for grouting cells of hollow units, <sup>3,4,5</sup> in. x in. (mm x mm)
Fine	1 (0.30)	$\frac{3}{4}$ (19.1)	$1\frac{1}{2} \times 2$ (38.1 x 50.8)
Fine	5.33 (1.63)	2 (50.8)	2 x 3 (50.8 x 76.2)
Fine	12.67 (3.86)	$2\frac{1}{2}$ (63.5)	$2\frac{1}{2} \times 3$ (63.5 x 76.2)
Fine	24 (7.32)	3 (76.2)	3 x 3 (76.2 x 76.2)
Coarse	1 (0.30)	$1\frac{1}{2}$ (38.1)	$1\frac{1}{2} \times 3$ (38.1 x 76.2)
Coarse	5.33 (1.63)	2 (50.8)	$2\frac{1}{2} \times 3$ (63.5 x 76.2)
Coarse	12.67 (3.86)	$2\frac{1}{2}$ (63.5)	3 x 3 (76.2 x 76.2)
Coarse	24 (7.32)	3 (76.2)	3 x 4 (76.2 x 102)

<sup>1</sup> Fine and coarse grouts are defined in ASTM C476.

<sup>2</sup> For grouting between masonry wythes.

<sup>3</sup> Minimum clear width of grout space and minimum clear grout space dimension are the net dimension of the space determined by subtracting masonry protrusions and the diameters of horizontal bars from the as-designed cross-section of the grout space. Grout type and maximum grout pour height shall be specified based on the minimum clear space.

<sup>4</sup> Area of vertical reinforcement shall not exceed 6 percent of the area of the grout space.

<sup>5</sup> Minimum grout space dimension for AAC masonry units shall be 3 in. (76.2 mm) x 3 in. (76.2 mm) or a 3-in. (76.2 mm) diameter cell.

*Reprinted with the permission of TMS*

## 2.1.6 Bearing Stress

Bearing stresses on masonry shall not exceed  $0.33 f'_m$

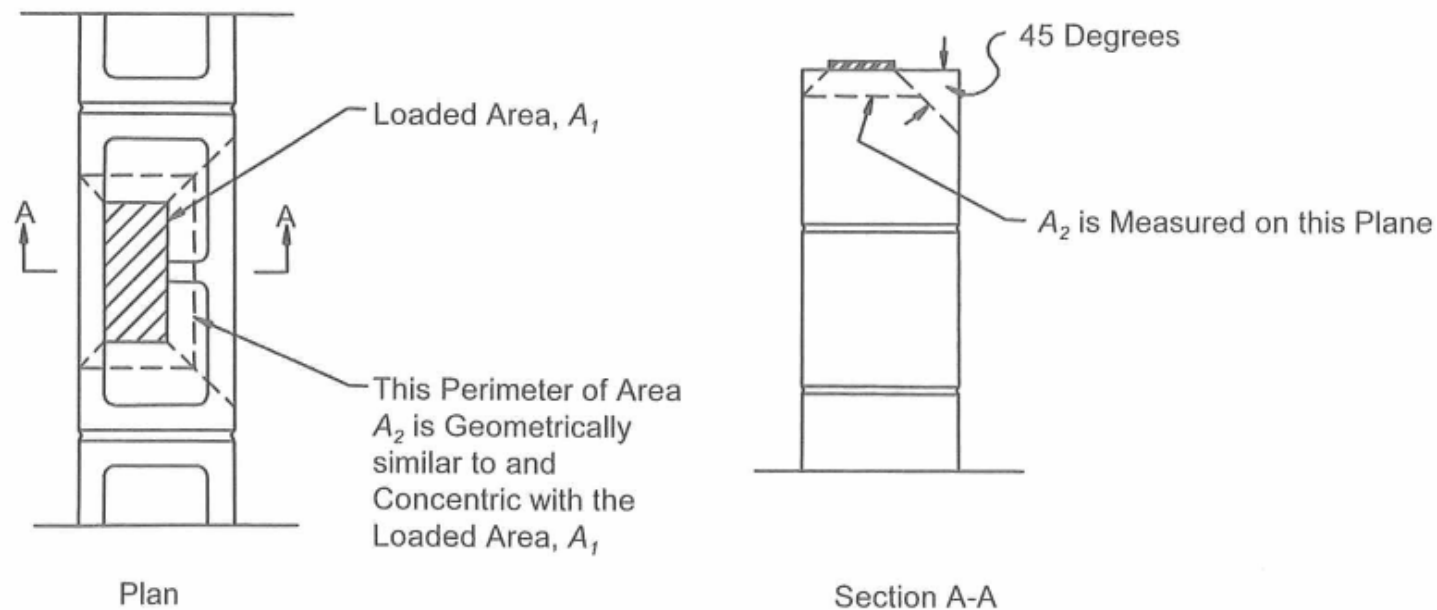
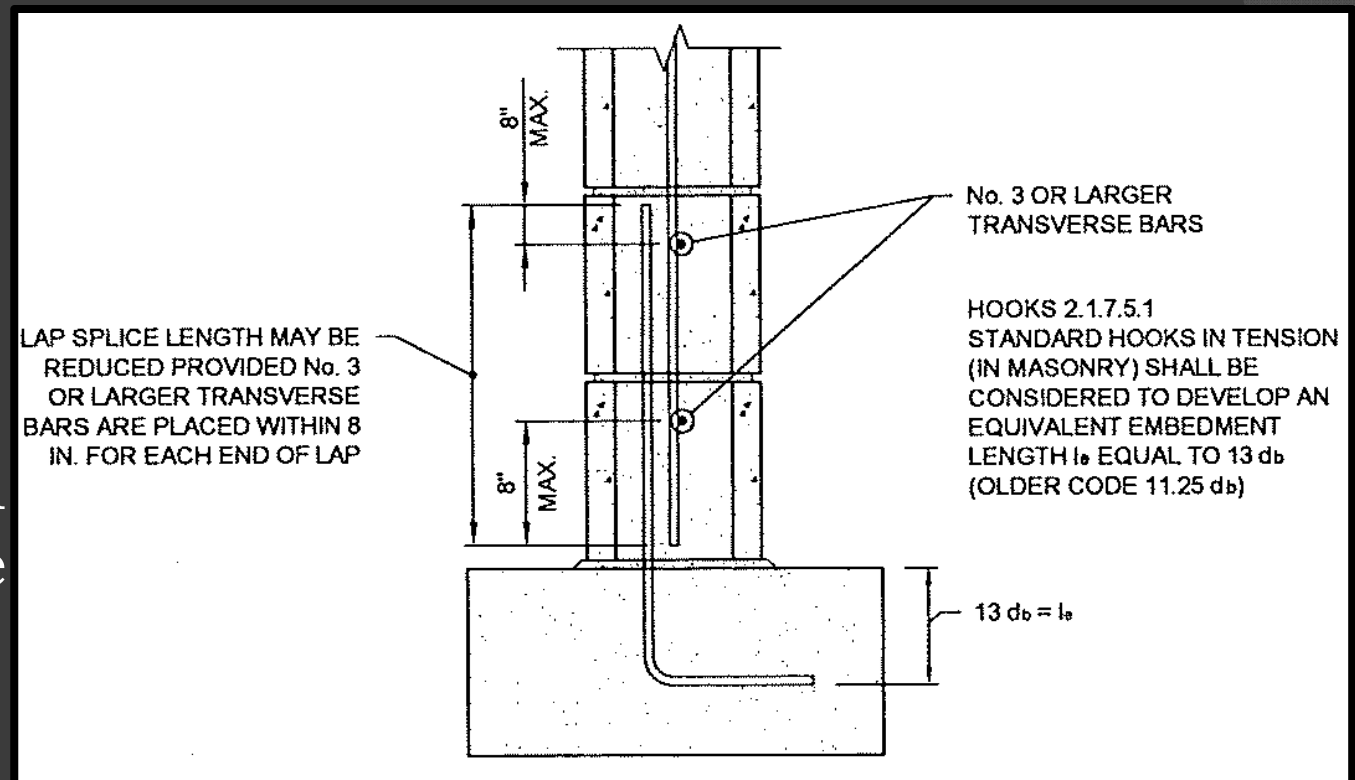

Figure CC-1.9-5 — Bearing areas

Reprinted with the permission of TMS

## 2.1.7.7.1.2 and 3.3.3.4 (b) Lap Splices

Confinement reinforcement of No. 3 or larger placed within the lap 8 inches or less from each end allows the lap length to be reduced by the factor  $\xi$ .



*Reprinted with the permission of TMS*

## 2.1.7.7.1.2 and 3.3.3.4 (b) Lap Splices

The maximum clear space between fully developed transverse bar and lapped bar shall be 1.5 inches in grouted masonry.

The reduced lap splice length shall not be less than  $36d_b$ .

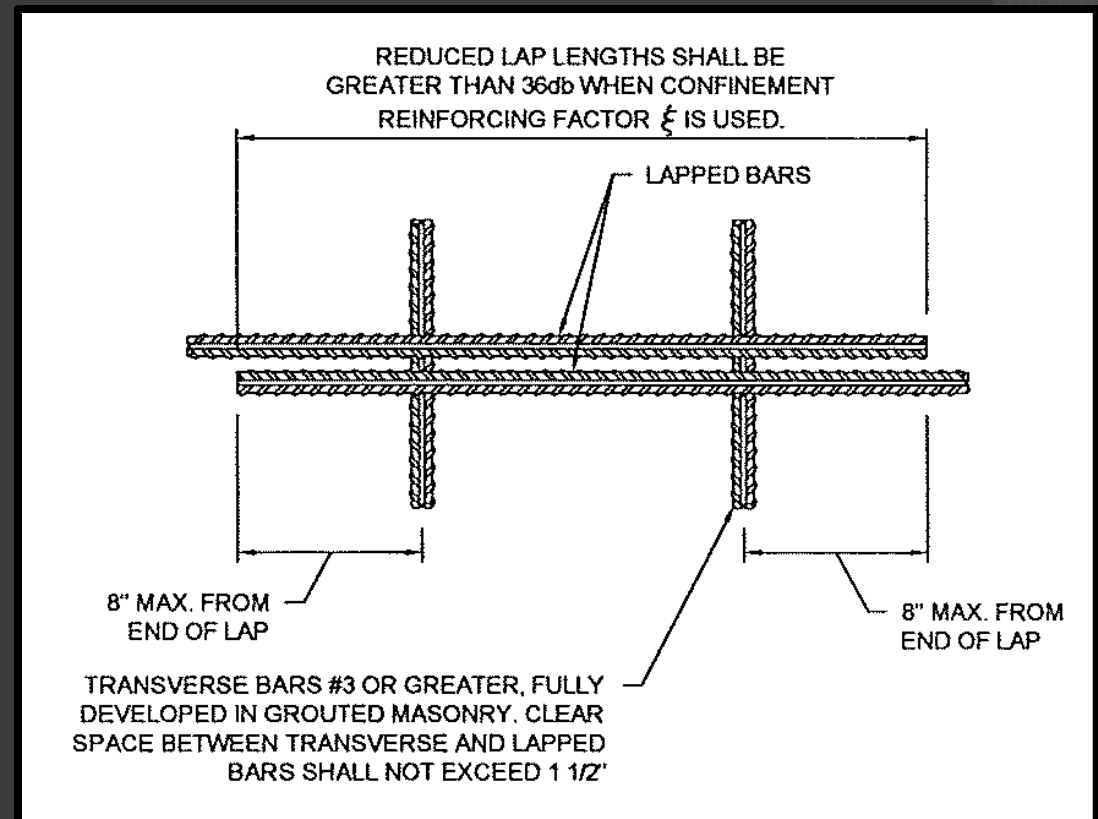

## 2.1.7.7.1.2 and 3.3.3.4 (b) Lap Splices

### Equation 2-13

$$\xi = 1.0 - (2.3 A_{sc} / (d_b)^{2.5})$$

$$\text{Where: } 2.3 A_{sc} / (d_b)^{2.5} \leq 1.0$$

$A_{sc}$  is the area of transverse bars at the end of the lap splice and shall have a maximum value of 0.35 in<sup>2</sup>.



# Table 2.2.3.2

## Allowable Flexural Tensile Stresses for Clay and Masonry, psi

Direction of flexural tensile stress and masonry type	Mortar types			
	Portland cement/lime or mortar cement		Masonry cement or air entrained portland cement/lime	
	M or S	N	M or S	N
Normal to bed joints				
Solid units	53 (366)	40 (276)	32 (221)	20 (138)
Hollow units <sup>1</sup>				
UngROUTED	33 (228)	25 (172)	20 (138)	12 (83)
Fully grouted	86 (593)	84 (579)	81 (559)	77 (531)
Parallel to bed joints in running bond				
Solid units	106 (731)	80 (552)	64 (441)	40 (276)
Hollow units				
UngROUTED and partially grouted	66 (455)	50 (345)	40 (276)	25 (172)
Fully grouted	106 (731)	80 (552)	64 (441)	40 (276)
Parallel to bed joints in masonry not laid in running bond				
Continuous grout section parallel to bed joints	133 (917)	133 (917)	133 (917)	133 (917)
Other	0 (0)	0 (0)	0 (0)	0 (0)

*Reprinted with the permission of TMS*

## 2.3.2 Design Assumptions

- a) Strain compatibility exists between the reinforcement, grout, and masonry.
- b) Strains in reinforcement and masonry are directly proportional to the distances from the neutral axis.

# 2008 TMS (Service ASD)

## TMS 402-08/ACI 530-08/ASCE 5-08

Given : Flexural Member



$$V = 20,000 \text{ lbs (near end)}$$

$$M = 80,000 \text{ ft lbs (mid-span)}$$

$$b = 7.625'' \quad f'm = 1,500 \text{ psi} \quad d = 38'' \quad h = 40''$$

$$f_v = V/bd = \frac{20,000\#}{(7.625'')(38'')} = 69 \text{ psi} \quad (\text{eq. 2-23})$$

$$F_v = \sqrt{f'm} = \sqrt{1,500 \text{ psi}} = 38.73 \text{ psi (controls for masonry shear resistance)} < 50 \text{ psi (eq. 2-24)}$$

$f_v > F_v$   shear reinforcement is required to resist entire shear

$$f_v = 69. \text{ psi} < 3\sqrt{f'm} = 116 \text{ psi} \quad (\text{eq. 2 - 27})$$

∴ Steel resisting all shear

# Minimum Shear Area Required for Steel Resisting All Shear Force

$$A_v = \frac{V_s s}{F_s d} \quad (\text{eq. 2-30})$$

Try #3 reinf  $A_v = 0.11 \text{ in}^2$

$$s = \frac{A_v F_s d}{V} = \frac{(0.11 \text{ in}^2)(24,000 \text{ psi})(38'')}{20,000\#} = 5''$$

$s = 5'' < d/2 = 19''$  or  $48''$  OK

Min #3 at 5'' o.c. req'd not practical

$$\#3 \text{ at } 5'' \text{ o.c. } \frac{0.11}{5''} = \frac{x}{8''} \longrightarrow x = 0.176 < 0.2 \text{ OK}$$

Use #4 at 8'' o.c. stirrups

# 2011 TMS (Service ASD)

## TMS 402-11/ACI 530-11/ASCE 5-11

Given : Flexural Member

$V = 20,000$  lbs (near end)

$M = 80,000$  ft lbs (mid-span)

$b = 7.625''$        $f'_m = 1,500$  psi     $d = 38''$      $h = 40''$

$$f_v = \frac{V}{A_{nv}} = \frac{20,000^\#}{(7.625'')(38'')} = 69 \text{ psi} \quad (\text{eq. 2-24})$$

$$F_v = F_{vm} + F_{vs} \quad (\text{eq. 2-25})$$

$$F_{vm} = \frac{1}{2} [(4 - 1.75(M/Vd)) \sqrt{f'_m}] + 0.25 P/A_n \quad (\text{eq. 2-28})$$

$M/Vd = 0$  (near end) ;     $M/Vd > 1$  (near mid-span)

$$F_v \leq 2\sqrt{f'_m} \quad \text{when } M/Vd \geq 1.0 \quad (\text{eq. 2-27})$$

$$F_{v\max} = 2\sqrt{1500} = 77.46 \text{ psi}$$

$$F_{vm} = \frac{1}{2} [(4 - 1.75(1))\sqrt{1,500}] = 43.57 \text{ psi}$$

{ M/Vd, need not exceed 1.0 }

$$f_v = 69 \text{ psi} < 77.46 \text{ psi (maximum limit o.k.)}$$

Determine required shear steel reinforcement:

$$F_{vs \text{ req'd}} = f_v - F_{vm} = 69 \text{ psi} - 43.57 \text{ psi} = 25.43 \text{ psi}$$

$$F_{vs \text{ req'd}} = 25.43 \text{ psi}; \quad \Rightarrow \quad F_{vs} = 0.5 \left( \frac{A_v F_s d}{A_n s} \right) \quad (\text{eq. 2-30})$$

Try #3 reinf:  $A_v = 0.11 \text{ in}^2$

$$s_{\text{req'd}} = \frac{(0.5)(0.11 \text{ in}^2)(32,000 \text{ psi})(38'')}{(7.625'')(38'')(25.43 \text{ psi})} = 9.08'' \rightarrow$$

$$s_{\text{req'd}} = 9'' < d/2 = 19'' \text{ or } 48''$$

(1.13.2.4) Min steel:

$$0.0007bd_v = 0.0007(7.65'')(40'') = 0.213 \text{ in}^2/\text{FT} < A_v/s = 0.3 \text{ in}^2/\text{ft} \text{ OK}$$

Use #4 at 8'' o.c. – stirrups

# 2008 TMS (Ultimate Strength)

TMS 402-08/ACI 530-08/ASCE 5-08

Given: Flexural Member

$$V_u = 24,000 \text{ lbs (near end)}$$

$$M_u = 96,000 \text{ ft lbs (mid-span)}$$

$$b = 7.625''$$

$$f'_m = 1,500 \text{ psi}$$

$$d = 38''$$

$$h = 40'' = d_v$$

$$V_n = V_{nm} + V_{ns} \quad (\text{eq. 3-19})$$

$M_u / V_u d_v \Rightarrow$  approaches greater than 1.0 at mid-span

$\Rightarrow$  Use  $M_u / V_u d_v = 1.0$



$$V_u \leq 4 A_n \sqrt{f'_m} \quad (\text{eq. 3-21})$$

$$A_n = (7.625'')(40'') = 305 \text{ in}^2$$

$$V_{n \text{ max}} \leq 4(305 \text{ in}^2) \sqrt{1,500 \text{ psi}} = 47,250\# \quad (\text{eq. 3-21})$$

$$\phi V_{n \text{ max}} = 0.8 V_{n \text{ max}} = 37,800\#$$

$$V_u = 24,000\# < \phi V_{n \text{ max}} = 37,800\# \text{ O.K.}$$

$$V_{nm} = [4 - 1.75 (M_u / N_u d_v)] A_n \sqrt{f'_m} + 0.25 P_u \quad (\text{eq. 3-22})$$

$$V_{nm} = [4 - 1.75 (1)] 305 \text{ in}^2 \sqrt{1,500} = 26,578\#$$

Need not exceed 1.0

Determine  $V_{ns}$  req'd:

$$V_n = V_{nm} + V_{ns} \quad (\text{eq. 3-19})$$

$$V_u / \phi = V_{nm} + V_{ns} \implies \frac{24,000^\#}{0.8} - 26,578^\# = V_{ns} \text{ req'd} = 3,422^\#$$

$$V_{ns} \text{ req'd} = 3,422^\# \implies V_{ns} \text{ req'd} = 0.5 (A_v/s) F_y d_v \quad (\text{eq. 3-23})$$
$$\implies s \text{ req'd} = (0.5)(0.11 \text{ in}^2)(60,000 \text{ psi})(40") / 3422^\# \implies = 38.5"$$

$s \text{ req'd} = 38" \text{ o.c.}$       ↙ try #3 stirrups

Max spacing  $\implies d_v/2 \text{ or } 48" \implies 20" \text{ o.c. max}$

Min steel  $\implies 0.0007bd_v =$

$0.0007(7.625")(40") = 0.213 \text{ in}^2 / \text{ft}$  ← controls

$A_v/S = 0.3 \text{ in}^2/\text{ft} > 0.213 \text{ in}^2/\text{ft}$  OK

**Use #4 stirrups at 8" o.c.**

# 2011 TMS (Ultimate Strength)

TMS 402-11/ACI 530-11/ASCE 5-11

Given: Flexural Member

$$V_u = 24,000 \text{ lbs (near end)}$$

$$M_u = 96,000 \text{ ft. lbs (mid-span)}$$

$$b = 7.625''$$

$$f'_m = 1,500 \text{ psi}$$

$$d = 38''$$

$$h = 40'' = d_v$$

$$V_n = V_{nm} + V_{ns} \quad (\text{eq. 3-20})$$

$$M_u / V_u d_v \Rightarrow 1.0 \quad (\text{greater than 1.0 at mid-span})$$

$$M_u / V_u d_v = 1.0 \text{ used}$$

$$\phi V_n \leq 4A_{nv} \sqrt{f'_m} \quad (\text{eq. 3-22}); \quad V_{n \max} = (4)(40'')(7.625'') \sqrt{1,500}$$

$$V_{n \max} = 47250\# \quad (\text{eq. 3-22})$$

$$\phi V_{n \max} = 0.8 V_{n \max} = 37,800\# \text{ OK}$$

$$V_u = 24,000\# < \phi V_{n \max} = 37,800\# \text{ OK}$$

$$V_{nm} = [(4 - 1.75 M_u / V_u d_v)] A_{nv} \sqrt{f'_m} + 0.25 P_u \quad (\text{eq. 3-23})$$

$$V_{nm} = [4 - 1.75 (1)] [(305 \text{ in}^2)] \sqrt{1,500} = 26,578\#$$

Determine  $V_{ns}$  req'd:

$$V_n = V_{nm} + V_{ns} \quad (\text{eq. 3-20})$$

$$V_u / \phi = V_{nm} + V_{ns} \implies \frac{24,000\#}{0.8} - 26,578\# = V_{ns} \text{ req'd} = 3,422\#$$

$$V_{ns} \text{ req'd} = 0.5(A_v/s)f_y d_v \quad (\text{eq. 3-24})$$

$$\Rightarrow s \text{ req'd} = (0.5)(0.11 \text{ in}^2)(60,000 \text{ psi})(40'')/3,422\# = 38.5''$$
$$s \text{ req'd} = 38'' \text{ o.c.}$$

$$\text{Max spacing} = h/2 = 20'' \text{ or } 48'' \quad (\text{sec. 3.3.4.2.3}) \Rightarrow 20'' \text{ o.c. max}$$

$$\text{Min reinf} \Rightarrow 0.0007bd = 0.0007(7.625'')(40'') = 0.213 \text{ in}^2/\text{ft}$$

controls

Section  $\{(1.13.2.4)/(3.3.4.2.3)\}$

$$A_v/S = 0.3 \text{ in}^2/\text{ft} > 0.213 \text{ in}^2/\text{ft} \quad \text{OK}$$

Use #4 stirrup at 8" o.c.

# Example Screenwall Verification

## TMS 402-08

Given: 8" CMU Block Cantilever Screen Wall, 8 ft tall

$$f'_m = 1500 \text{ psi}$$

$$d = 3.81" \text{ (bars centered at wall)}$$

$$E_m = 900 f'_m = 1,350,000 \text{ psi} \quad \text{TMS 402-08}$$

(1.8.2.2.1)

$$E_s = 29,000,000 \text{ psi} \quad \text{TMS 402-08}$$

(1.8.2.1)

$$N = E_s / E_m = 29E6 / 1,350,000 = 21.48$$

$$M = (20 \text{ psf})(8')(1')(4') = 640 \text{ #}'$$

$$V = (20 \text{ psf})(1')(8') = 160 \text{ #}'$$

Ignore Axial Load

Try #4 at 32" o.c.

$$0.2/32 = x/12$$

$$0.075 \text{ in}^2/\text{ft}$$

$$\rho = A_s/bd = \frac{0.075 \text{ in}^2}{(12'')(3.81'')} =$$

$$0.00164; np = 0.03524$$

$$k = \sqrt{2n\rho + (n\rho)^2} - n\rho = 0.2325$$

$$j = 1 - k/3 = 0.92248$$

$$npj = 0.032508$$

$$f_m = M/bd^2(2/jk) = \frac{(640^{\#'} \times 12''/\text{ft})}{(12'')(3.81'')^2} \{2/[(0.92248)(0.2325)]\}$$

$$= 411 \text{ psi} < (1500/3)(1.33) 665 \text{ psi}$$

$$f_s = M/bd^2(n/npj) = \frac{(640^{\#'} \times 12''/\text{ft})}{(12'')(3.81'')^2} \left( \frac{21.48}{0.032508} \right) =$$

$$29,133 \text{ psi} < (24,000)(1.33) 31,920 \text{ psi}$$

# Example Screenwall Verification

## TMS 402-11

$$f_m = 411 \text{ psi} < 0.45 f'_m = 675 \text{ psi} \quad \text{OK}$$

↖ TMS 402-11, (2.3.4.2.2)

$$f_s = 29,133 \text{ psi} < 32,000 \text{ psi} \quad \text{OK}$$

↖ TMS 402-11, (2.3.3.1)

#4 at 32" o.c. centered in 8" block OK for both TMS 402-08 and TMS 402-11

Note: TMS 402-11 has adjusted values to be approximately greater by 1/3 than previous codes, for allowable compressive strength of masonry and of steel reinforcement



## 2.3.2 Design Assumptions

- c) Stress is linearly proportional to the strain.
- d) Stresses remain in the elastic range.
- e) Masonry in tension does not contribute to axial and flexural strength.

## COMMENTARY

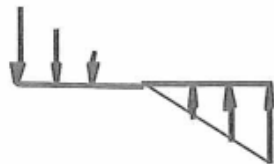
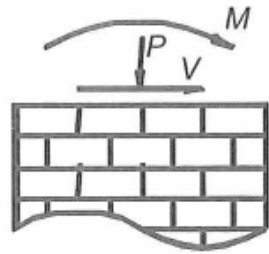

Flexure



Axial

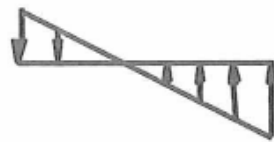

Combined Flexure  
and Axial

Shear  $f_v = \frac{V}{A_n}$

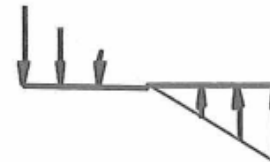
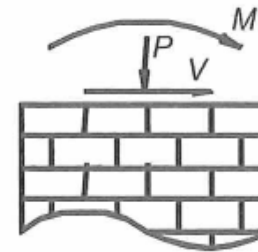

Flexure



Axial

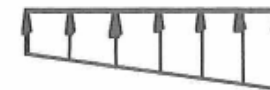

Combined Flexure  
and Axial

Shear  $f_v = \frac{V}{A_n}$

*Figure CC-2.3-4(a) — Illustration of design section that is subjected to tension*

*Figure CC-2.3-4(b) — Illustration of design section that is not subjected to tension*

*Reprinted with the permission of TMS*

# Steel Reinforcement Allowable Stresses

1. Grade 60 reinforcement: 32,000 psi (2.3.3.1)
2. Joint reinforcement shall not exceed 30,000 psi (2.3.3.2)
3. The compressive resistance of steel reinforcement shall be neglected unless tied.

## 2.3.4.2.2 Allowable Forces and Stresses

The compressive stress in masonry due to flexure or flexure in combination with axial load shall not exceed  $0.45 f'_m$ .

## 2.3.4.3 Columns

Design axial loads shall be assumed to act with a minimum eccentricity of 0.1 times side dimension.

## 2.3.6 Shear

Shear stress in masonry shall be determined by:

$$f_v = V/A_{nv} \quad \text{Eq. 2-24 (2.3.6.1.1)}$$

$f_v$  shall be less than allowable shear stress:

$$F_v = F_{vm} + F_{vs} \quad \text{Eq. 2-25 (2.3.6.1.2)}$$

## 2.3.6.1.2 Shear

$F_v$  shall not exceed the following:

(a) Where  $M/(Vd) \leq 0.25$ :

$$F_v \leq 3 \sqrt{f'_m} \quad \text{Eq. 2-26}$$

(b) Where  $M/(Vd) \geq 1.00$ :

$$F_v \leq 2 \sqrt{f'_m} \quad \text{Eq. 2-27}$$

(c) Maximum value of  $F_v$  for  $M/(Vd)$  shall be linearly interpolated between 0.25 and 1.0

## 2.3.6.1.3 Shear

Allowable shear stress resisted by the masonry,  $F_{vm}$ :

$$F_{vm} = \frac{1}{2} [(4.0 - 1.75 (M/vd))\sqrt{f'_m}] + 0.25 P/A_n \quad \text{Eq. 2-28}$$

$M/(Vd)$  is a positive number and need not be taken greater than 1.0.

## 2.3.6.1.4 Shear

Allowable shear stress for special reinforced masonry shear walls, by the masonry,  $F_{vm}$ :

$$F_{vm} = \frac{1}{4} \left[ (4.0 - 1.75 (M/vd)) \sqrt{f'_m} \right] + 0.25 P/A_n$$

Eq. 2-29

$M/Vd$  is a positive number and need not be taken greater than 1.0.



## 2.3.6.1.5 Shear

Allowable shear stress by steel reinforcement,  $F_{vs}$ :

$$F_{vs} = 0.5 (A_v F_s d / A_n s) \quad \text{Eq. 2-30}$$

Shear reinforcement shall be provided where  $f_v$  exceeds  $F_{vm}$

2.3.6.2

## 3.1.7 Nominal Bearing Strength

The nominal bearing strength of Masonry shall be computed at  $0.8 f'_m$  multiplied by the bearing area,  $A_{br}$ .

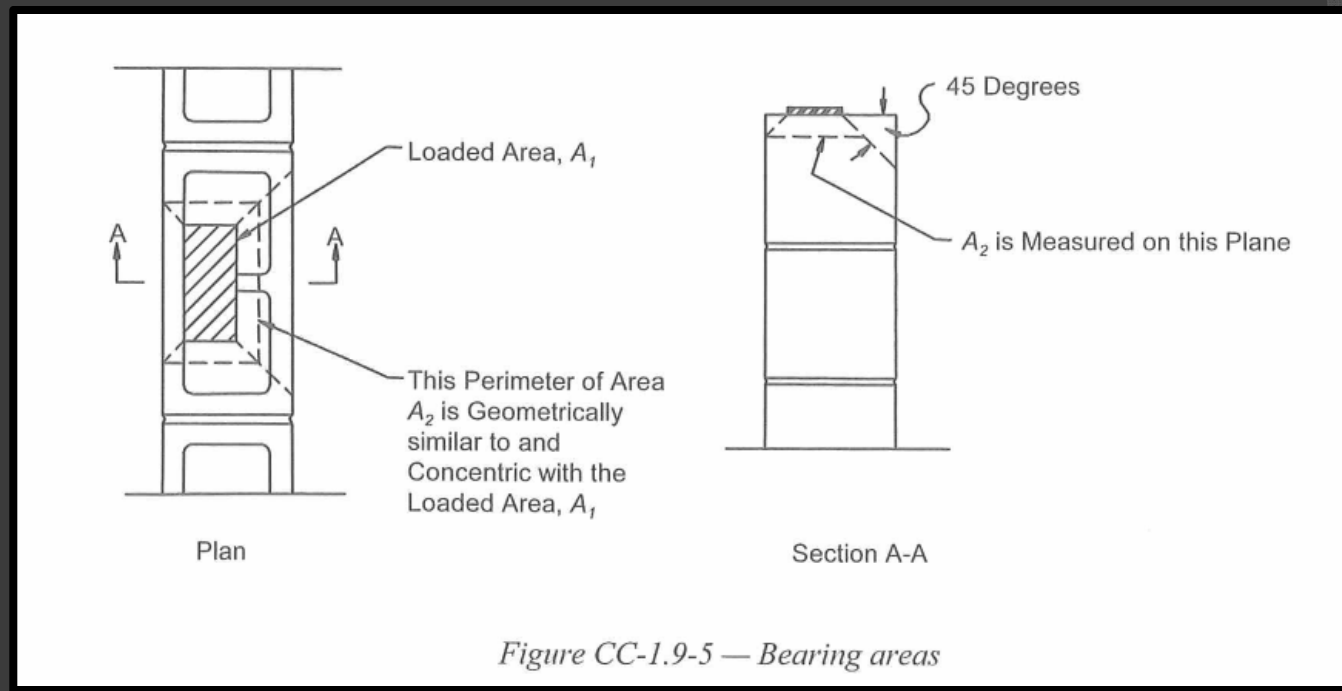

Reprinted with the permission of TMS

## 3.3.5.5 Deflections

The modulus of rupture,  $f_r$ , for the cracking moment of a wall shall come from Table 3.1.8.2 and the neutral axis for the cracking moment on inertia ( $I_{cr}$ ) shall be per Section 3.3.2.

The effects of axial load shall be permitted when calculating  $I_{cr}$ .

## 3.3.5.5 Deflections

The cracked moment of inertia for a wall, partially or fully grouted, and the neutral axis is in the face shell:

$$I_{cr} = n \left[ A_s + \frac{P_u}{f_y} \frac{t_{sp}}{2d} \right] (d - c)^2 + \frac{bc^3}{3} \quad \text{Eq. 3-31}$$

$$c = \frac{A_s f_y + P_u}{0.64 f'_m b}$$

Eq. 3-32

# Chapter 4

## Prestressed Masonry

1. Determination of  $d$  for lateral unrestrained prestressing tendons (4.4.3.5.3).
2. Ratio of  $a/d$  shall not exceed 0.38 (4.4.3.6).
3. New equation for  $f_{ps}$  for walls laterally restrained or lateral unrestrained unbonded prestressing tendons (Eq. 4-3).

# Typical Anchorage and Coupling Devices for Prestressed Masonry

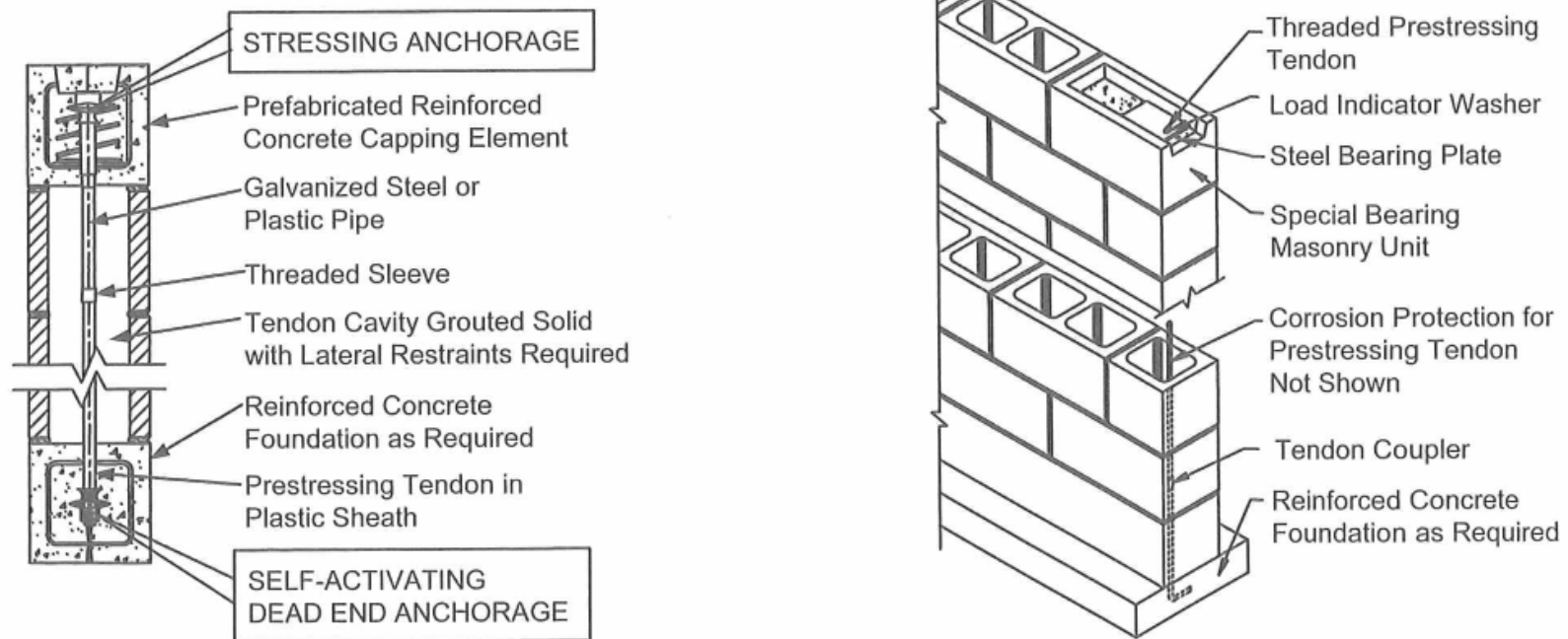

Figure SC-4 — Typical anchorage and coupling devices for prestressed masonry

Reprinted with the permission of TMS

# Chapter 6 Veneer

## Prescriptive Requirements for Anchored Masonry Veneer

1. Anchored masonry veneer shall not be used in areas where the strength level velocity pressure,  $q_z$ , exceed 40 psf (6.2.2.1).
2. Minimum attachment of anchor to steel framing at least a #10 corrosion-resistant screw (6.2.2.7.2).

# Chapter 6 Veneer

## Prescriptive Requirements for Anchored Masonry Veneer

3. Minimum attachment of anchor to wood backing at least a 8d ring-shank corrosion-resistant nail or a #10 corrosion-resistant screw in seismic design Category D. (6.2.2.10.2.3)



## Requirements in Areas of High Winds (6.2.2.11)

Requirements in areas where the strength level velocity pressure,  $q_z$ , exceeds 40 psf but does not exceed 55 psf and the building's mean roof height is less than or equal to 60 feet.

# Chapter 7

## Glass Unit Masonry

1. Figure 7.2-1 factored design wind pressure for glass unit masonry. (7.2.1)
2. Limits on thin units to 32 psf. (7.2.2)
3. Factored wind pressure does not exceed 16 psf. (7.2.3.1)
4. Factored wind pressure exceed 16 psf. (7.2.3.2)

# Chapter 8

## Strength Design Of Autoclaved Aerated Concrete Masonry

1. Reinforcement strength (8.1.8.6)
2. Nominal bearing strength (8.1.9.1)
3. Corbels (8.1.10)
4. Maximum usable strain (8.3.3.5)
5. Nominal sliding shear strength (8.3.4.1.2)

# All New Appendix B

## Design of Masonry Infill

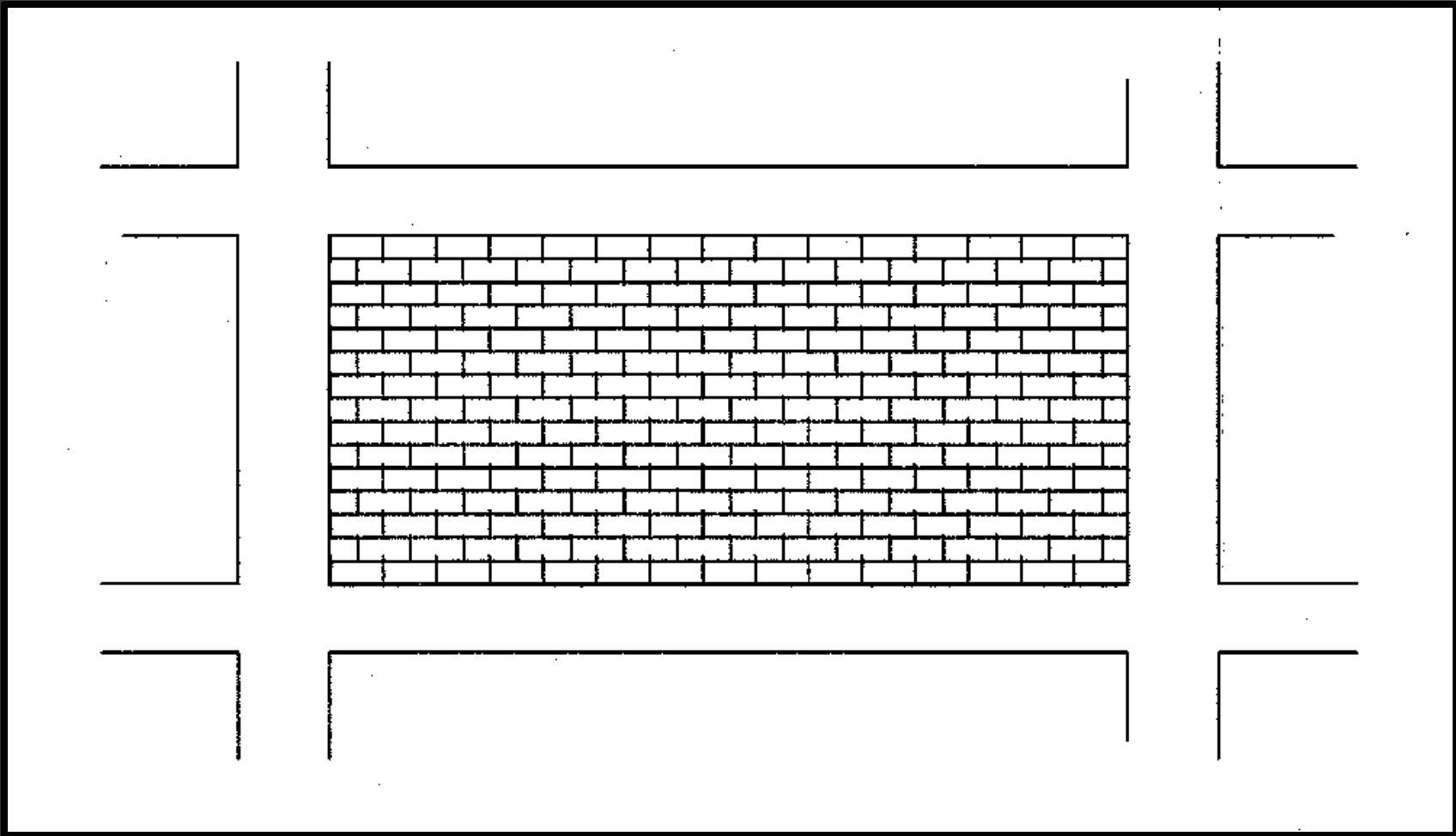

# Overview of Changes to 2012 IBC Direct Design (2101.2.7)

Masonry designed by the direct design method shall comply with the provisions of TMS 403-10.

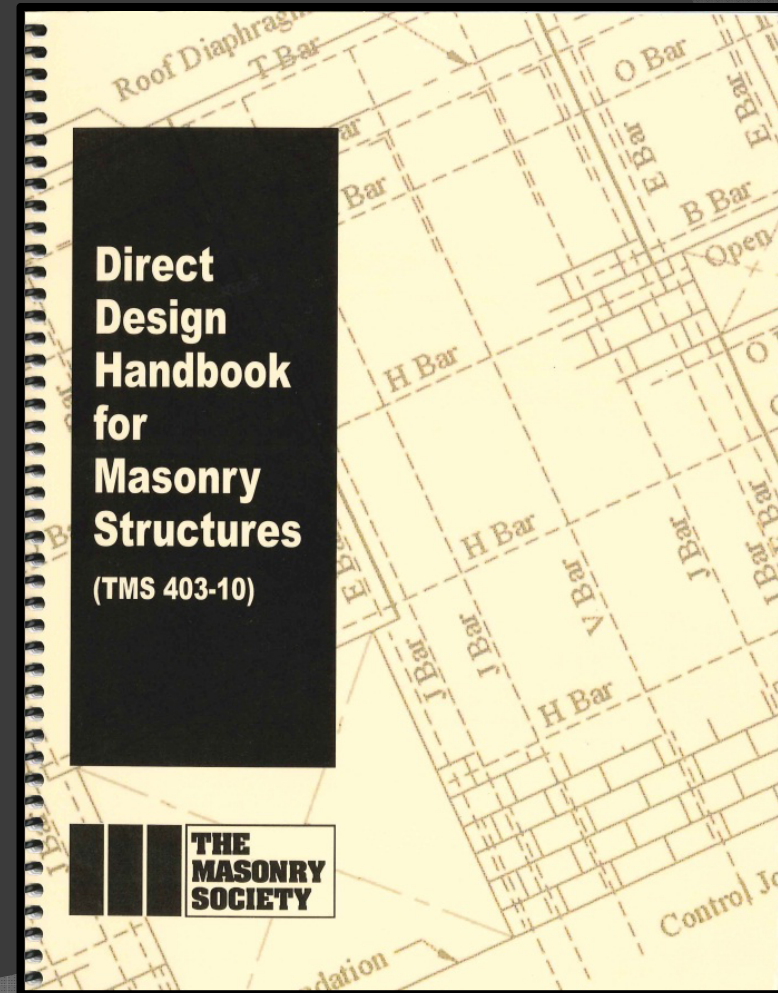

## 2103.5 Architectural Cast Stone

Architectural cast stone shall conform to the requirements of ASTM C1364.



# Quality Assurance

- Unit Strength Method (2105.2.2.1)  
Tables 2105.2.2.1.1 and 2105.2.2.1.2 at  
Level B Quality Assurance
- Prism Test Method (2105.2.2.2)

# Allowable Stress Design

Lap splices per Section 2107.2.1 in lieu of MSJC Section 2.1.8.7.1.1.

Minimum length of lap splices for reinforcing bars in tension or compression,  $l_d$ .

$$l_d = 0.002 d_b f_s$$

Not less than 40 bar diameters.



# IBC Chapter 2109.3

## Code Additions

- Adobe Construction (2109.3)
- Unstabilized Adobe (2109.3.1)
- Stabilized Adobe (2109.3.2)
- Detailed Requirements (2109.3.4)
- Number of Stories (2109.3.4.1)
- Mortar (2109.3.4.2)

## Masonry Heaters (2112)

- Seismic Reinforcing (2112.4)

## Masonry Chimneys (2113)

- Seismic Reinforcing (2113.3)
- Seismic Anchorage (2113.4)

# MSJC Specifications and Commentary

Many of the items that have changed in the MSJC Code have also changed in the Specifications and Commentary.

Northwest Concrete Masonry Association presents  
**Structural Masonry Design Webinar**  
A PRACTICAL SEMINAR FOR PRACTICING ENGINEERS



Dates for three sessions:

Oct. 11, 16, 18, 2012

Time:

4-6:30 pm Pacific Time

Continuing Education Credit (up to 7.5 PDH) available  
For more information contact NWCMA at [www.nwcma.org](http://www.nwcma.org) or  
(425) 697-5298

# MASONRY DESIGN USING TMS 402-11 AND 2012 IBC

Questions and answers.

